

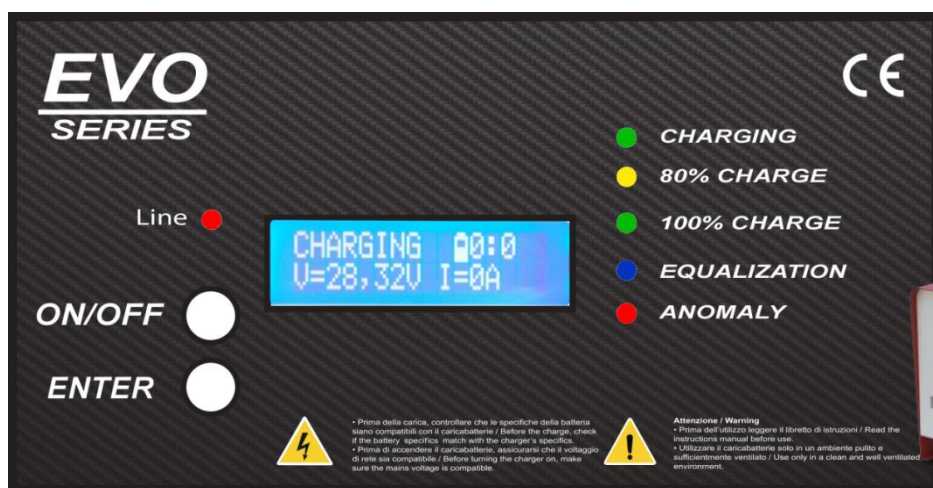

EVO

SERIES



Instructions Manual

EN



CAREFULLY READ THE FOLLOWING INSTRUCTIONS BEFORE CONNECTING THE DEVICE TO THE MAINS VOLTAGE AND/OR TO THE BATTERY. ALSO MAKE SURE THAT THE SIZE OF THE DEVICE IS ADEQUATE TO THE BATTERY CONNECTED TO IT.

INTRODUCTION

The battery chargers produced by T.C.E. Srl offer many unique features comprehensively described in this manual.

Carefully read these instructions to use the device at its best and avoid potential problems in future.

T.C.E. Srl strongly advises to carefully follow all information and advice mentioned to guarantee safe use of the device

The correct utilization of the device will increase its working life and maximize efficiency.

In case of suggestions, advices or error noticed in this manual, your notifications will be very much appreciated to improve the quality of our service.

Thank you for your trust in choosing our product

For further information, technical details, brochures or illustrative material visit our website www.tcechargers.com

INDEX

| | |
|--|----|
| INTRODUCTION | 2 |
| 1. SAFETY & RISKS | |
| 1.1. Proper use of the product and general suggestions | 4 |
| 1.2. Risks caused by the network and charging current | 5 |
| 1.3. Risks caused by the acid, gas and toxic vapors | 5 |
| 1.4. Protecting third parties | 5 |
| 1.5. Safety devices | 6 |
| 1.6. Device serial code label | 6 |
| 1.7. Certifications | 6 |
| 2. CHARGING CURVES | |
| 2.1. Standard charging curve(Wa) | 7 |
| 2.2. Fast charging curve | 7 |
| 2.3. Equalization charge | 7 |
| 2.4. Maintenance charge | 7 |
| 3. INSTALLATION | |
| 3.1. Connection of the device to the network | 8 |
| 3.2. Power transformer connections | 8 |
| 3.3. Power transformer connections (on a 60Hz network) | 10 |
| 4. CONTROL CARD | |
| 4.1. Charging visuals and data visuals | 11 |
| 4.2. Special visualizations | 12 |
| 4.3. Control card programming | 13 |
| 4.4. Control card software update | 13 |
| 4.5. Connectors cable color sequence | 14 |
| 5. HOW TO OPEN THE DEVICE (Box “E”) | |
| 5.1. External view | 15 |
| 5.2. Opening | 15 |
| 5.3. Internal view | 16 |
| 6. HOW TO OPEN THE DEVICE (Box “P”) | |
| 6.1. External view | 17 |
| 6.2. Opening | 17 |
| 6.3. Internal view | 18 |
| 7. MAINTENANCE & PROBLEM SOLVING | |
| 7.1. Periodic maintenance | 19 |
| 7.2. Error codes | 19 |
| 7.3. Error codes description and possible causes | 19 |
| 7.4. Problem solving | 20 |
| 7.5. Device does not power on | 20 |
| 7.6. Wiring diagrams | 21 |
| WARRANTY | 23 |

1. SAFETY & RISKS

1.1. Proper use of the product and general suggestions

The product is built by following high qualitative standards to guarantee its reliability and safety.

Every inadequate use of the device can cause:



- Wounds or death to the user and/or to third party
- Damage to the device and/or to other materials or real or personal goods
- Damage to the environment near the device
- Inadequate and inefficient operations compared to the standard working state of the device

The personnel involved with the use of the device must:



- Have a qualification degree in the use of electrical / electronic devices
- Carefully read the manual to understand the proper and correct functioning of the device
- Respect the rules mentioned in this manual
- Use only the correct tools when doing standard maintenance or when repairing a fault on the device

In case of other signs or indication attached to the device for safety reasons, they must:

- Be in a legible and comprehensible state for everyone
- Not to be damaged
- Not to be removed
- Not to be covered with other signs/stickers or painted with paint or color of any kind

The use of the device implies:



- A carefully reading of the manual and follow the instructions
- Perform periodical maintenance to maintain the device in an optimal state
- **ALWAYS** follow the instructions written on the battery from its producer

This device must be used **EXCLUSIVELY** to fulfill its purpose. Every other non-compliant use of the device will be reputed inadequate and will lead to the void of the warranty.

Every damage caused to the device, persons, real and personal property by an inadequate use of the device cannot be accused to the producer.

The device **MUST** be used only in networks with ground connection and with fuse or magnetic protection in the plug..

T.C.E. Srl declares that the device has a protection degree **IP21**.

Before the utilization of the device, perform a quick visual inspection to make sure that there is no visual damage that could compromise the correct functioning of its operations.

In case of ascertain damages on the charger or on the safety devices that could compromise its functioning, they must be repaired immediately before starting the charging cycle.



Do not remove, cut off or modify in any way any of the many safety devices installed inside and/or outside the charger.

Before starting a normal charging cycle, also check the battery conditions:

- Make sure that there is no dirt or foreign objects on top of the battery
- Make sure the battery is in good condition
- Make sure that there are no short circuits or faulty cells
- Check the water level of the battery before any charge
- Check the condition of the connectors (make sure that the contacts inside the plug are in optimal condition)

In case of suspected or ascertained damage to the battery or charger, do not start the charging cycle and contact a technician.

1.2. Risks caused by the network and charging current



The wrong utilization of the device can leave the operator open to many risks: for example risks of electrocution or risks of electromagnetic fields that could cause cardiac problems to peacemaker users.

An electric shock can be fatal, to avoid electric shocks during the usage of the device:

- Do not touch any live wire inside the device or directly connected to it
- **NEVER** touch the battery poles connected to the device
- Do not short circuit the cables of the device or the charging plug

All the cables must be checked to make sure that there is no damage, they are insulated and well sized for the device.

Loose cable connection, burn marks, damage of different kind or wrong size must be **IMMEDIATELY** addressed.

1.3. Risks caused by Acid, Gas and toxic vapors



The batteries charged by our device contain acid which can be dangerous for health and can cause serious problems to the eyes and/or the skin in case of direct contact.

In case of direct contact with the acid, use water to wash it away and seek medical advice.

T.C.E. Srl advises to always wear personal protection equipment when carrying out maintenance operations to both the battery and chargers.



During the standard operations of the device, gases and vapors are released from the battery which can cause health problems. These gases and vapors are also highly explosive.



The correct use of the device requires the use of a well ventilated environment to prevent the accumulation of such gases and avoid risks of explosions.

Charging rooms with less than 4% of Hydrogen in the air are reputed safe against explosions caused by gases. Good ventilation provides a safe and reliable working environment for charging operations.

During the charge, T.C.E. Srl advises to keep **AT LEAST** a 80cm distance between the charger and the battery and to keep well away from any object that could cause or could be the origin of sparks and/or flames.

To avoid problems or damage caused by gas, vapor or acid, T.C.E. Srl suggests:

- Do not remove the charging plug during the charging cycle
- Do not inhale the gas or vapor released by the battery during the charge
- Make sure that the battery being charged is in a well-ventilated area
- Do not leave any foreign objects on top of the battery during the charge

1.4. Protecting third parties



While the device is in function, it is advised to keep all non-authorized personnel away from the charger.

In case of any personnel whom have necessity to go near the device during the charging cycle, T.C.E. Srl suggests:

- To warn them about the dangers caused by the device while in function (gas, dangers of electrocution and charging currents, electromagnetic fields, etc. etc.)
- Provide the necessary PPE (gloves, helmets, etc. etc.)
- Try to avoid direct contact between the device and non-authorized personnel

1.5. Safety devices

The charger is equipped with many different safety devices to guarantee a reliable and safe use.

The inbuilt safety features ensure good condition of the battery, the charger and of the near environment.

The control card offers safety on the charging cycle, it monitors the different charging phases making sure that the value recorded and read are always inside the range of optimal values for the connected battery.

The fuse installed inside the device offers protection against short circuit and reverse polarity.

All T.C.E. Srl devices have many safety timers to offer reliability during night charges or during the weekends when the battery is left attached to the charger for the equalization cycle.

1.6. Device serial code label

Attached on the side of every device produced by T.C.E. Srl there is a label with a unique serial code number belonging to the device and some useful information.

The label is anti-tampering and has the purpose to give information regarding the period of time when the device was produced.

If the label is damaged or tampered with, the warranty will be considered void.



- 1) T.C.E. Srl contact info
- 2) CE Marking
- 3) Model and size
- 4) Device serial code
- 5) Suggested battery size for the device
- 6) Power supply
- 7) Frequency 50hz or 60hz
- 8) Device absorption in VA
- 9) Charging curve
- 10) IP protection degree
- 11) Date of production

1.7. Certifications

The devices with the **CE** mark satisfy the requirements for the electromagnetic compatibility.



2. CHARGING CURVES

2.1. Standard charging curve (Wa)



The standard charging curve of the devices produced by T.CE. Srl is the Wa.

It is characterized by a crescent curvature of the charging voltage and proportionally a de-crescent curvature of the charging current.

The maximum duration of the Wa charging curve is about 10-12h.

It is ideal to charge lead acid traction batteries.

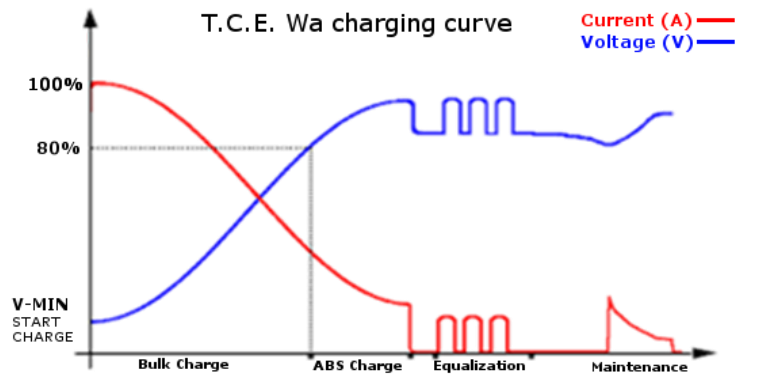

2.2. Fast charging curve



The fast charging curve is applied only to the EVO Series under request.

The fast charging curve is slightly different compared to the traditional Wa charging curve because the initial current is much more higher. This allows the battery voltage do rise faster reducing the charging times.

The duration of the charge with the fast charging curve is about 8-10h.

It is ideal to charge lead acid traction batteries.

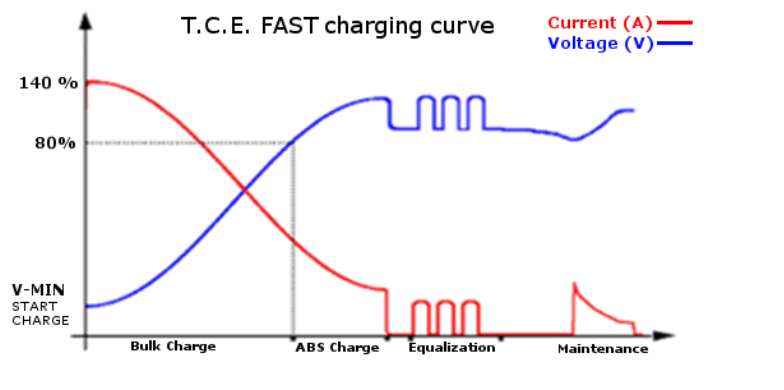

2.3. Equalization charge



The equalization charge is integrated in the software of all our devices.

It is completely automatic and begins its cycle after 10h of the end of the normal charge.

The equalization charge is made of impulses that are short charging cycles made in sequence and they allow the balancing of the cells voltage and electrolyte density that make the battery pack. It can also be considered a light desulphation process.

2.4. Maintenance charge



The maintenance charge is integrated in the software of all of T.C.E. Srl devices.

It is completely automatic and activates when the equalization charge is complete.

The control card reads the battery voltage values, should the values read are below a pre-set range, it will operate the charge just enough to allow the battery always be in an optimal state ready to be used.

3. INSTALLATION

IMPORTANT:
Dedicated section for the technician and qualified personnel

- 3.1. Connection of the device to the network Before connecting the device to the mains electricity supply (AC voltage), make sure that the network is suited for it and matches the specifics supplied by T.C.E. Srl



In case the specifics are not a match, the device might not function properly and could have some consequences, such as:

- Errors during the charge
- Incomplete charge
- Damaging of the protection fuse
- Damaging of the electronic components
- Damaging of the battery

Make sure that the power transformer inside the device is connected properly based on the network voltage.

- 3.2. Power transformer connections Measure the network voltage during the time band destined to the charge and select the matching connection on the power transformer and auxiliary transformer.



During some time bands (ex. Morning or daily), the mains voltage can change because of voltage peaks caused by other machinery in the company or caused by other companies in the nearest areas.

Make sure that the network is stable and use an instrument in optimal working condition to make the readings.



The EVO Series offers a connection:

- Three Phase from 220/380 Vac to 250/440 Vac (see example "A" and "B")
- Single Phase from 220 Vac to 240 Vac (box "P", see example "C")
- Single Phase from 220 Vac to 255 Vac (box "E", see example "C")

To match the network voltage on the power transformer change the position of the black cable (see example "A" and "C").

To change position, simply loose the tighten screw on top of the terminal block, remove the black cable and plug it into the matching terminal block with the desired voltage. Make sure the screws are tightened properly.

In case of three phase network from 220 Vac to 250 Vac, it will also be necessary to change the connections of the blue cables.

The blue cables are connected **from the zero of one phase to the phase of another phase**, as shown in the example "B".

IMPORTANT: *in case of changes in the connection on the power transformer, it is also necessary to change the connections on the auxiliary transformer to guarantee an optimal functioning of the control card.*

Upper view of the auxiliary power transformer.

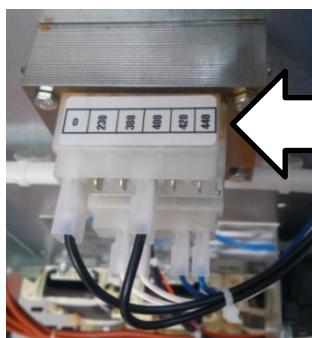

Terminal block to select the mains AC voltage

THREE PHASE connection

Power transformer upper view

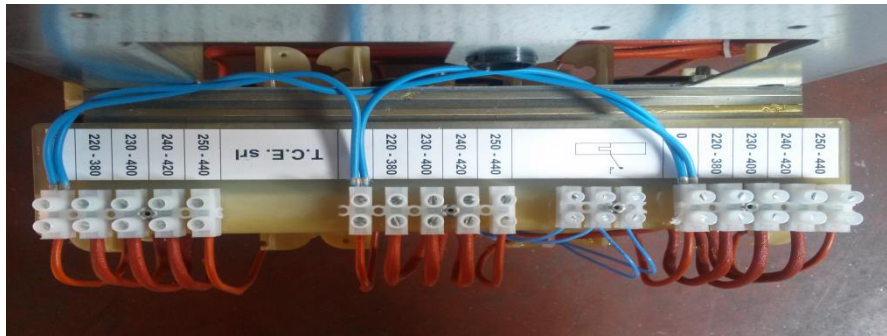

Example of connection to a three phase network with voltage 380 Vac (Example A)

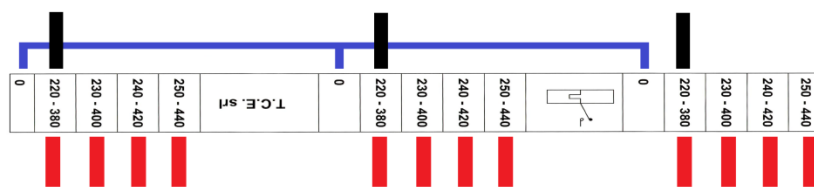

Example of connection to a three phase network with voltage 220 Vac (Example B)

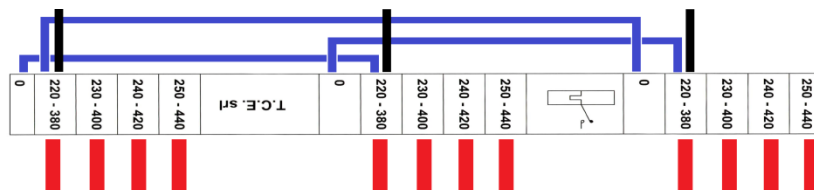

SINGLE PHASE connection

Power transformer upper view

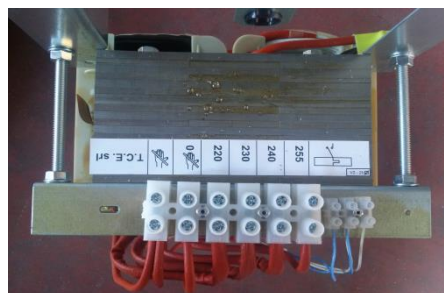

Box "E"

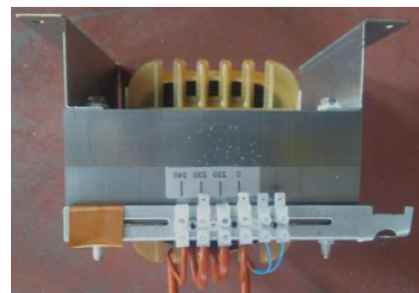

Box "P"

Example of connection to a single phase network with voltage 240 Vac (Example C)

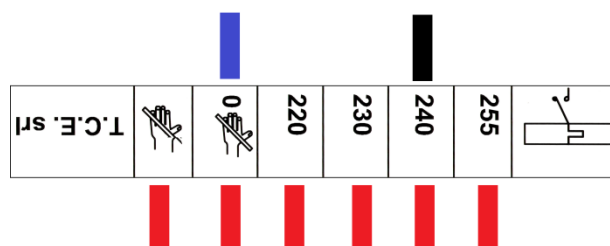

- 3.3. Power transformer connections (on a 60Hz network)



THREE PHASE 60Hz connection

Power transformer upper view



Example of connection to a three phase network with voltage 380 Vac and 60Hz (Example A)

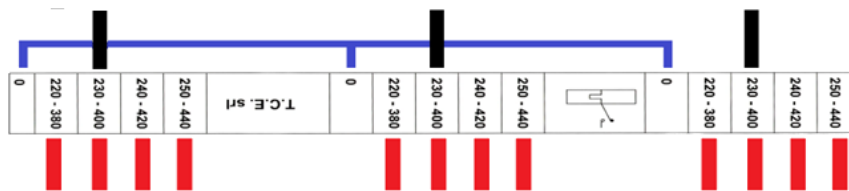

Example of connection to a three phase network with voltage 220 Vac and 60Hz (Example B)

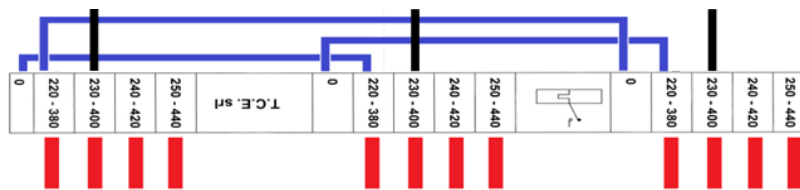

SINGLE PHASE 60Hz connection

Power transformer upper view

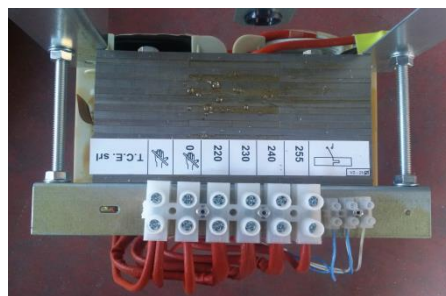

Box "S"

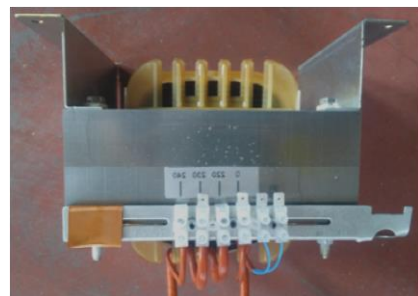

Box "M"

Example of connection to a single phase network with voltage 240 Vac and 60Hz (Example C)

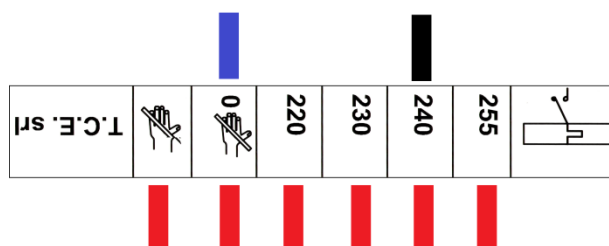

4. CONTROL CARD

4.1. Charging visuals and data visuals

During the charge it is possible to visualize various parameters and information which is recorded and read by the device.

The different visuals offer a tool which helps to understand the charging phase and the battery status.

When the device is successfully connected to the network, the LEDs will turn on in sequence to indicate the execution of a quick initial test.



The **first visual** indicates the size of the device (as shown on the image on the right 48V 100A).



When the battery is already connected to the charger, the charge will automatically start



When there is no battery connected the **NO BATTERY!** Visualization will appear.

The **main visualization** appears on the display when the charging cycle begins and displays the main values such as:

- Length of the charging phase (HH:MM)
- Battery voltage (V)
- Charging current (I)

In case of interruption of connection between the charger and the battery (whether intended or accidental), the charge will automatically stop and the first visualization with the battery size will reappear.



The **ABS visualization** appears on the display when the battery charging status reaches 80%

By pressing the **ENTER** button is possible to navigate between the various visuals of information related to the current charging cycle.



The **ERROR visualization** indicates the error occurred during the charging cycle.

The errors are shown with a letter that correspond to a determined error, malfunction or anomaly found during the charging cycle.

To read all the errors, please refer to the **Maintenance** section of the manual.



The **Residual Time visualization** indicates an approximate remaining time until the end of the charge.

The time shown can vary approximately +/- 20% from the real effective remaining time. The value will appear after approximately 1h after the begin of the charge.



The **Out Power visualization** indicates the instant consumption of the device in Kw and the Ampere hour delivered to the battery.



The **TIME visualization** indicates the duration of the final charging phase (from 80% to 100%) and the total length of the charging cycle.

It is possible to change the timer of this phase by following the instructions on the next section "Special visualizations".

- 4.2. Special visualizations The control cards used by T.C.E. Srl offer the possibility to change some parameters to allow an improved charging result based on the battery conditions.

**IMPORTANT:
Dedicated section for the
technician and qualified
personnel**

To access the **SET ABS** (set absorption) visualization, keep the 2 buttons pressed together (“ON/OFF” and “ENTER”) for a few seconds

The default absorption value is 4h, to increase the duration of the final charging phase use the “ENTER” button to navigate and select the desired length, then press the “ON/OFF” button to confirm the selection.



After the **SET ABS** visualization, the **LANGUAGE** visualization will appear. Use the “ENTER” button to navigate and select the desired language, then press the “ON/OFF” button to confirm the selection.



The supported languages are:

- English
- Italian
- Spanish

At the end of the language selection, the first visualization will appear.

- 4.3. Control card programming

The control cards supplied with our devices are universal; they can be adapted to any T.C.E. Srl battery chargers by following a simple and quick procedure.

The sequence of this procedure are:

- Adapt the jumper on the back of the card based on the voltage of the battery charger

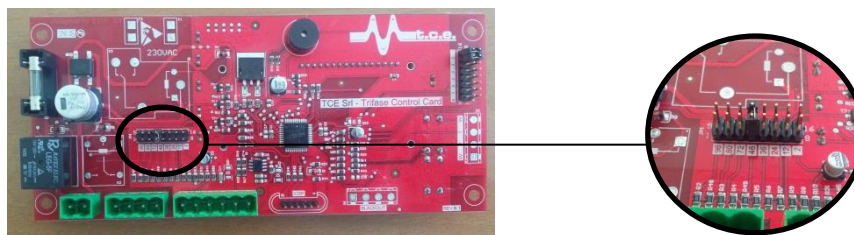

- Keep the two buttons pressed together (“ENTER” and “ON/OFF”) and turn on the device.

As soon as the visualization **nominal voltage** appears (ex. 24V), release the two buttons.

Select the desired voltage by navigating through the options with the “ENTER” button and select the desired size with the “ON/OFF” button.

- After the voltage selection visualization, the visualization **nominal current** will appear (ex.20A)

Navigate with the “ENTER” button to choose the desired size then use the “ON/OFF” button to select.

- **The control card is now ready for the current calibration, connect a battery with adequate voltage for the charger and start the charge.**

Move into the **ERORR** visualization and, while the charger is in function, keep the 2 buttons pressed together at the same time for a few seconds.

A new visualization will appear for the **charging current calibration**.

By using a tool to read the charging current, insert the same value read on the instrument in the visualization, using the “ENTER” button to navigate and the “ON/OFF” button to select the correct value.

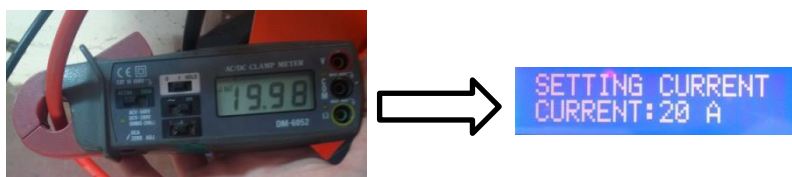

The control card will automatically interrupt the charging cycle for a few seconds and it will resume it with the correct current reading value.

4.4. Control card software update

By using a PicKit3 programmer, supplied by T.C.E. Srl, it is possible to update the software of the control card with a newer version.

To update the software, follow this procedure:

- Connect the PicKit3 programmer to a standard Power Bank



- Connect the programming cable to the control card. Make sure that the colour of the cable which is positioned in correspondence of the white arrow on the programmer, has the same colour connected in correspondence with the white arrow on the card.



- Press the button on the programmer, the red LED will blink for a few seconds. After that it will become blue to indicate the correct upgrade of the software.



- Remove the programming cable and install the card on the charger.

At the end of this procedure, repeat the programming procedure mentioned on the point 4.3.

4.5. Connectors cable color sequence

It is extremely important to follow the right colour sequence on the control card connectors, a wrong connection could cause a fatal fail of the card or bad charging value reading.

The correct color sequence of the cables is as shown on the images below.

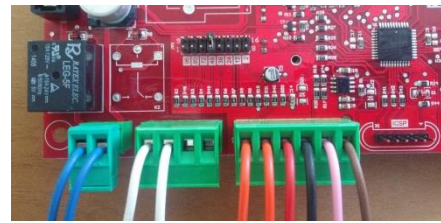
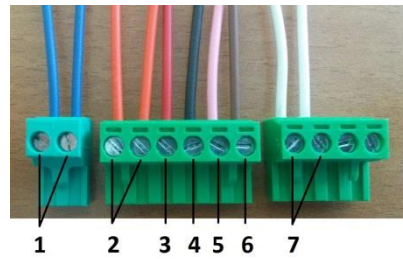

- 1- 2 x blu
- 2- 2 x orange
- 3- Red
- 4- Black
- 5- Pink
- 6- Brown
- 7- 2 x white

5. HOW TO OPEN THE DEVICE (Box "E")

IMPORTANT:
Dedicated section for the technician and qualified personnel

5.1. External view

Box measures:

- Width 400mm
- Height 900mm
- Depth 600mm



5.2. Opening



Before opening the device, make sure that:

- The battery is not connected
- The supply cables are not connected
- The device is in a flat and stable surface

If the device must be moved prior to opening, be extremely careful as tip-over could cause internal damage, hurt the operator or damage objects around it.

To open the device please follow the 4 steps:

- 1) Remove the screws on the back part of the cover



- 2) Push back the cover and pull it upwards

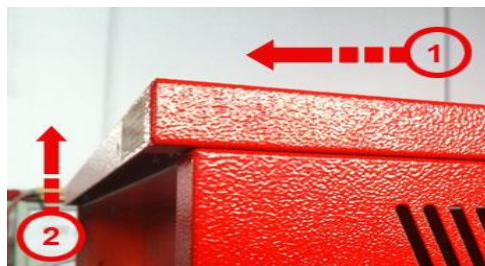

- 3) Remove the front part by removing the 2 screws on the front panel, top section, pull upwards and then outwards.

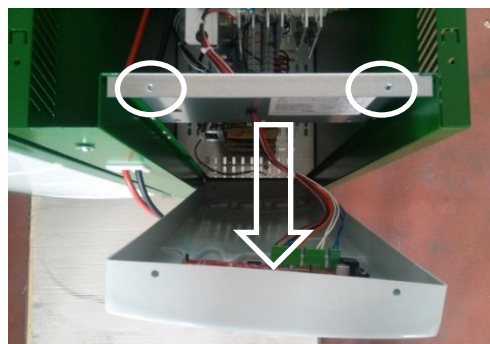

- 4) Remove the connectors from the control card to completely remove the front panel from the charger (optional)



5.3. Internal view

Once the charger is open, is possible to view all the internal components from either the side or from the front, allowing quick and simple access to maintain the charger.

From the top is possible to directly access to the DC fuse to check its integrity.

It's possible to access to the shunt for the reading of the current.

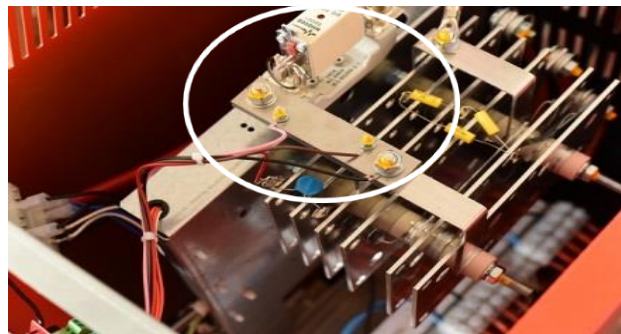

The auxiliary transformer can be easily reached from the top, should it be necessary to adjust the VAC input on the power transformer terminal block.

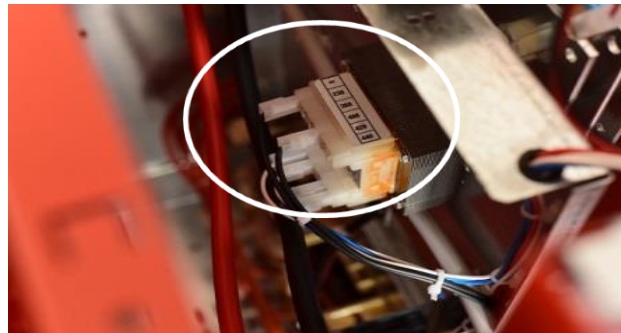

From the front part is possible to easily access to the contactor and also the power transformer.

The front panel access makes it easy to carry out maintenance operations and also the adjustment of connection regarding the input voltage (check section 3.2. Power transformer connections).



It is also possible to check the correct wiring of the control card and its condition.

6. HOW TO OPEN THE DEVICE (Box "P")

IMPORTANT:
Dedicated section for the technician and qualified personnel

6.1. External view

Box measures:

- Width 400mm
- Height 300mm
- Depth 300mm



6.2. Opening



Before opening the device, make sure that:

- The battery is not connected
- The supply cables are not connected
- The device is in a flat and stable surface

If the device must be moved prior to opening, be extremely careful as tip-over could cause internal damage, hurt the operator or damage objects around it.

To open the device please follow the 4 steps:

- 1) Remove the 4 screws to the left and right side of the device



- 2) Open the cover by pulling out towards the sides and pull up

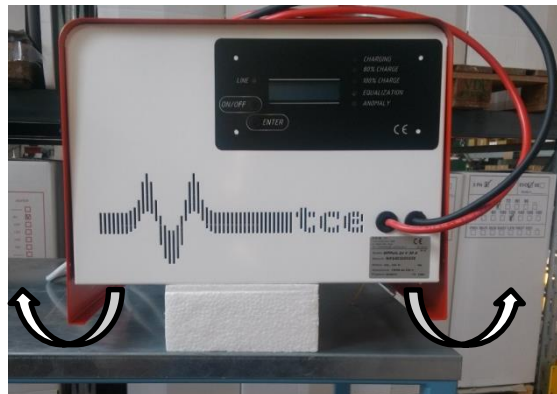

It is possible to remove the ground connection to gain better access to the internal parts of the device.

To perform the opening operation, it is suggested to put the device on a stand to allow a better removal of the cover part.

6.3. Internal view

Once the device is open, it is possible to directly access to all the electronic and mechanical components.

It is possible to check the control card wiring status



The connections of the power transformer are located directly on the side of the device; a sticker indicates where to connect the cable based on the network voltage (check section 3.2. Power transformer connections).



The DC fuse is located on the opposite side of the power transformer connections, making it simple and easy to change if required.

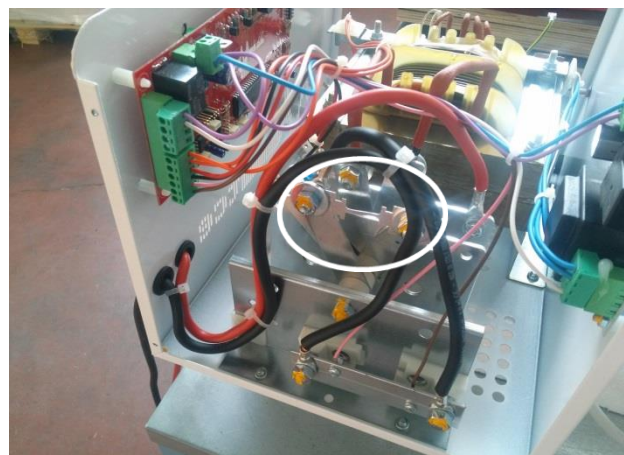

7. MAINTENANCE & PROBLEM SOLVING

IMPORTANT:
Dedicated section for the technician and qualified personnel

7.1. Periodic maintenance

To guarantee an optimal working state of the device, T.C.E. Srl advises to undertake periodic maintenance every 12 months.



The steps of this maintenance are:

- Make a quick visual check of the internal state of the device
 - Blow the dust away with compressed air
 - Check the screws on the power transformer connection blocks to make sure they are tighten
 - Make sure that the DC fuse is in good conditions
 - Check the status of both input and output cables and also the DC battery plug
-

7.2. Error codes

Should malfunctions or anomalies occur during the charge cycle, the control card indicates error codes in the ERROR visualization.



The error codes are:

- T+
 - V+
 - C+
 - Time Exceeded
-

7.3. Error codes description and possible causes

Description and possible causes of error code T+

The code T+ indicates the closing of the thermal coupler inside the power transformer. The cause is overheating of the internal core of the power transformer.

The possible causes of this code are:



- Environment temperatures too high to allow the optimal charging operations of the device
- Battery too discharged
- Wrong input connection on the power transformer
- Battery problems
- Battery size is not adequate for the charger

This error does not indicate a serious malfunctions or anomaly, it indicates that the charge was temporarily stopped during its cycle. Once the temperature goes below a certain level, the charge will automatically restart.

Description and possible causes of error code V+

The code V+ indicates a battery voltage too high compared to the allowed values.

The possible causes of this code are:



- Battery over charged
- The jumper on the back of the control card is connected on the wrong voltage (reference section 4.3. Control card programming)
- Battery voltage is not adequate for the charger

Description and possible causes of error code C+

The code C+ indicates a charging current too high compared to the allowed values.

The possible causes of this code are:

- Battery too discharged
- Wrong input connection on the power transformer

Description and possible causes of error **TIME EXCEEDED**

The code TIME EXCEEDED indicates the passing of one of the many safety timers.

The charge was not able to reach a determined value in the preset amount of time for that phase.

The possible causes for this code are:

- Wrong input connection on the power transformer
- Battery not in good condition

7.4. Problem solving

It is possible to solve the majority of the problems caused by these error codes by following these instructions.



Error code T+ problem solving

To solve the problems that cause the error code T+, make sure that:

- The orange cables on the control cards are properly tighten and in good conditions
- Change the position of the charger to a better environment with more air flow and lower temperature
- Check the battery size and status



Error code V+ problem solving

To solve the problems that cause the error code V+, make sure that:

- The battery capacity is adequate to the charger size
- The battery is not too charged
- The jumper on the back of the control card is connected to the right voltage (reference section 4.3. Control card programming)
- The DC fuse is in good conditions
- The cables red and black on the control card are properly connected to the diode's bridge (reference section How to open the device 5. and 6.)
- The diode's bridge is not damaged
- The battery is in an adequate state for the charge
- The plug contacts are in good conditions

Error code C+ problem solving

To solve the problems that cause the error code C+, make sure that:

- The battery is not too charged
- The connection on the power transformer is matching the mains network voltage
- Battery is in good condition

7.5. Device does not power on

Should the charger not switch on once the installation procedure has been carried out, check the following.



- The status of the network plug is in good condition
- The power transformer connection matches the network voltage
- The DC fuse inside the device is in good condition
- The wiring of the control card connectors are in good conditions
- The screws on the power transformer block are tighten properly
- The output voltage of the auxiliary transformer is correct
- There is voltage going to the power transformer

7.6. Wiring diagrams



Three-Phase wiring diagram Box "E"

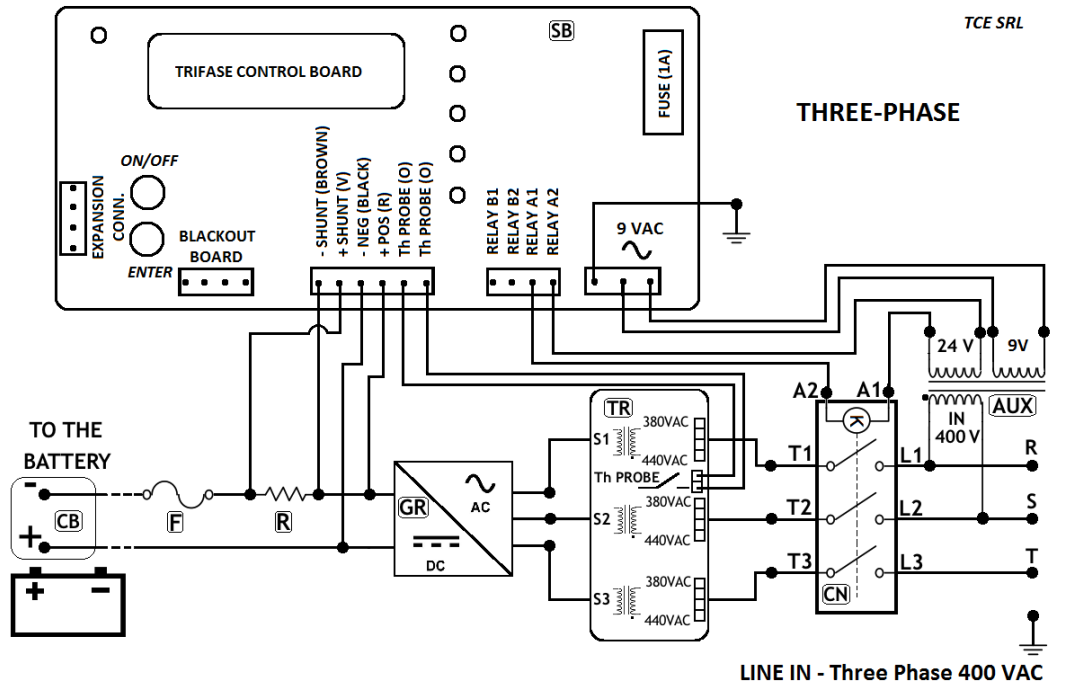

LINE IN - Three Phase 400 VAC

| | | | |
|------------|---------------------------------|-----------|----------------------------------|
| AUX | Auxiliary transformer | SB | Control board |
| CN | Tri-pole contactor | R | Shunt current measurement |
| TR | Flux leakage transformer | F | Safety fuse |
| GR | Three-phase diode bridge | CB | Output battery cables |

Single-Phase wiring diagram Box "E"

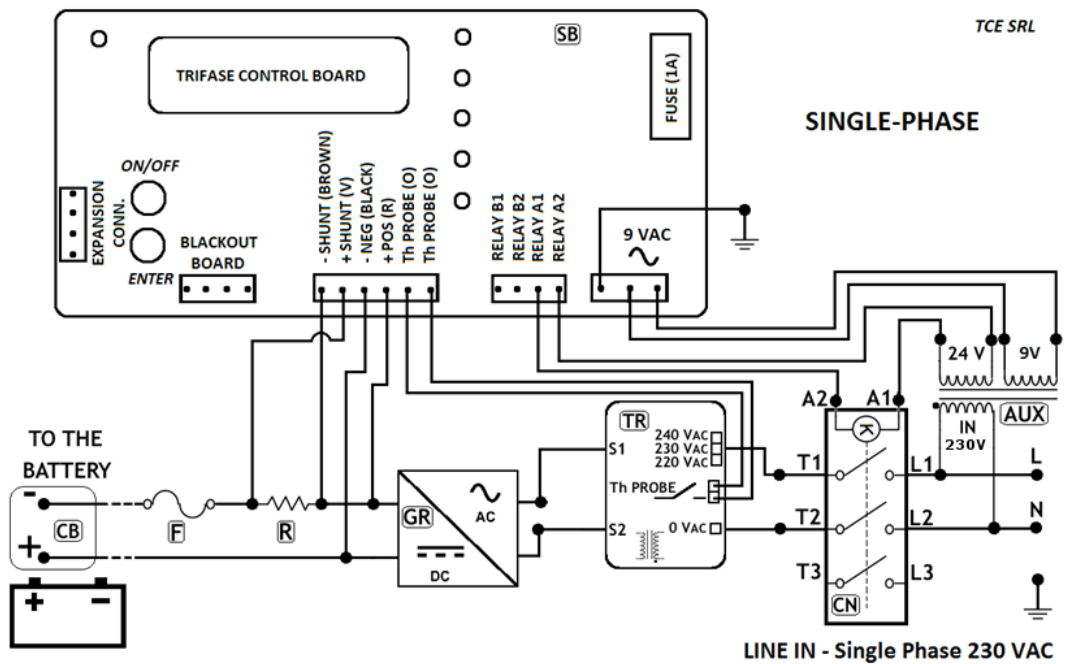

LINE IN - Single Phase 230 VAC

| | | | |
|------------|---------------------------------|-----------|----------------------------------|
| AUX | Auxiliary transformer | SB | Control board |
| CN | Tri-pole contactor | R | Shunt current measurement |
| TR | Flux leakage transformer | F | Safety fuse |
| GR | Three-phase diode bridge | CB | Output battery cables |

Single-Phase wiring diagram Box "P"

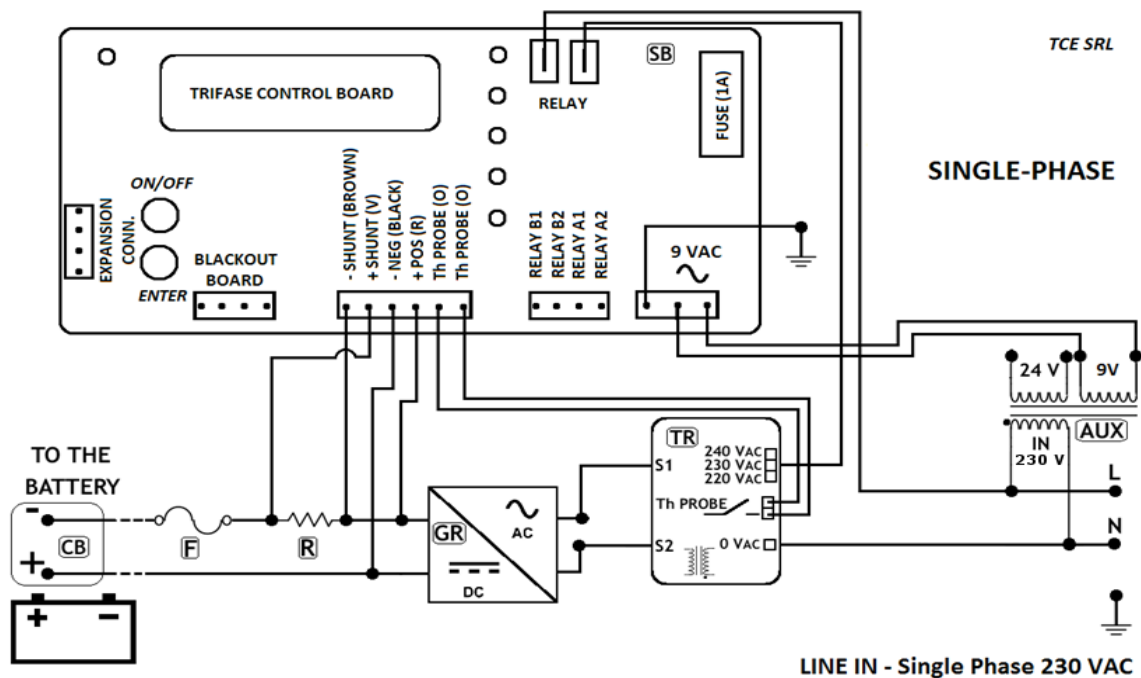

| | | | |
|-----|--------------------------|----|---------------------------|
| AUX | Auxiliary transformer | SB | Control board |
| CN | Tri-pole contactor | R | Shunt current measurement |
| TR | Flux leakage transformer | F | Safety fuse |
| GR | Three-phase diode bridge | CB | Output battery cables |

Three-Phase wiring diagram Box "E" – FAST charging curve

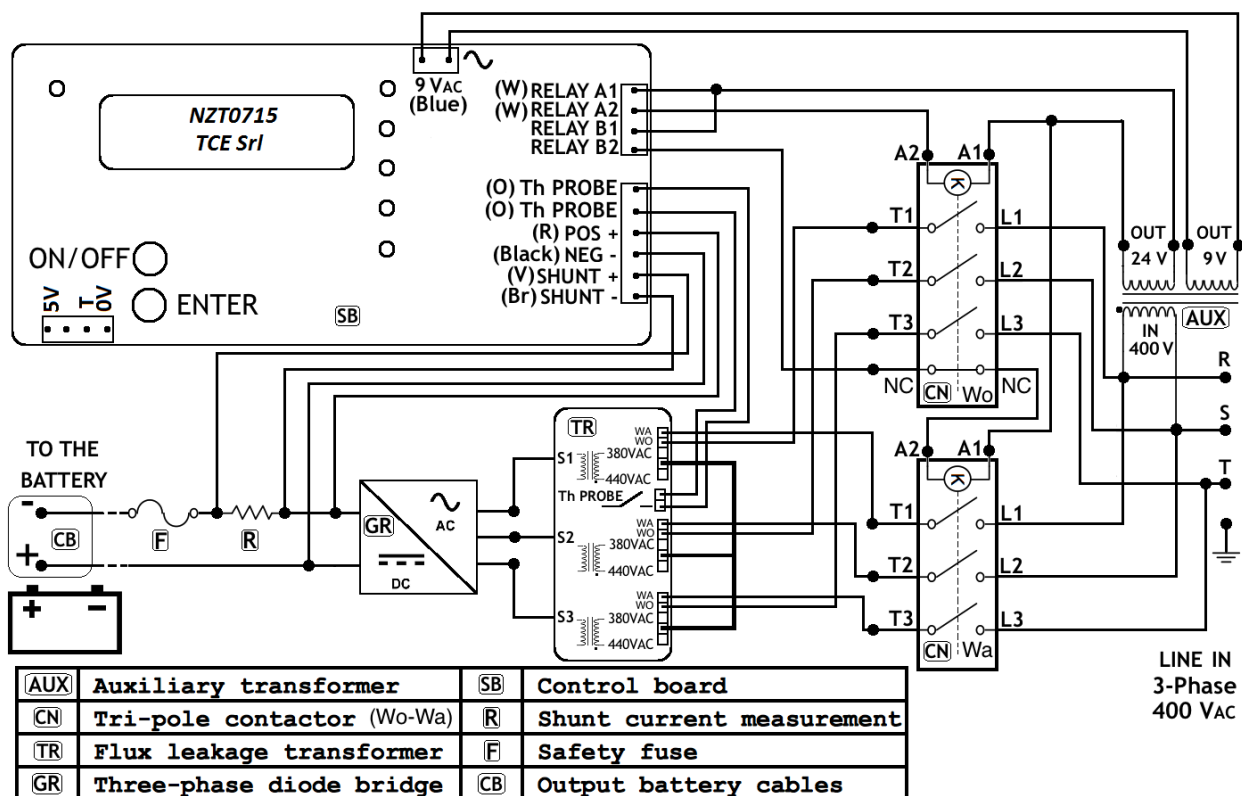

| | | | |
|-----|----------------------------|----|---------------------------|
| AUX | Auxiliary transformer | SB | Control board |
| CN | Tri-pole contactor (Wo-Wa) | R | Shunt current measurement |
| TR | Flux leakage transformer | F | Safety fuse |
| GR | Three-phase diode bridge | CB | Output battery cables |

WARRANTY

This device is built by following high qualitative standards to assure its high quality. Every single construction phase is overviewed by specialized personnel.

The warranty is granted ONLY AND IF T.C.E. Srl agrees that the damage claimed is caused by faulty parts installed during the construction or assembly of the device.

In the event of a warranty claim, the customer will have to dispatch the unit in question to T.C.E. Srl, if it is then deemed that the fault/damage was caused by faulty parts installed during the constructions or assembly, T.C.E. Srl will provide a replacement of the faulty part/component to restore the optimal state of the device.

The duration of the warranty is 24 months from the moment when the unit leaves T.C.E. Srl warehouse.

The warranty IS NOT GRANTED if:

- The unit has been tampered with
- The unit has been damaged by misuse and/or bad installation
- The unit has been damaged by a use that is not what it was built for
- The unit has been damaged by third party or environment causes (ex. Heavy rain, storms, etc etc)
- The unit has been damaged by the surrounding environment (ex. Alkaline environment)
- The unit has been damaged during transportation

This warranty does not cover in any case the replacement of the device or any compensation for costs, injuries, direct or indirect damages caused by unit fault (production stop included).

For any legal claims, the court of Padova (Italy) will be responsible and will handle the matter.

To request assistance or in case of problems, contact the closest authorized dealer or directly contact T.C.E. Srl.

Signature

T.C.E. s.r.l.
via G. Di Vittorio n°5
35046 Saletto (PD)
P.IVA e C.F.: 01385440282